

## High Productivity Cooking Steam Rectangular Boiling Pan, 300lt Hygienic Profile with Backsplash & Tap

ITEM # \_\_\_\_\_

MODEL # \_\_\_\_\_

NAME # \_\_\_\_\_

SIS # \_\_\_\_\_

AIA # \_\_\_\_\_

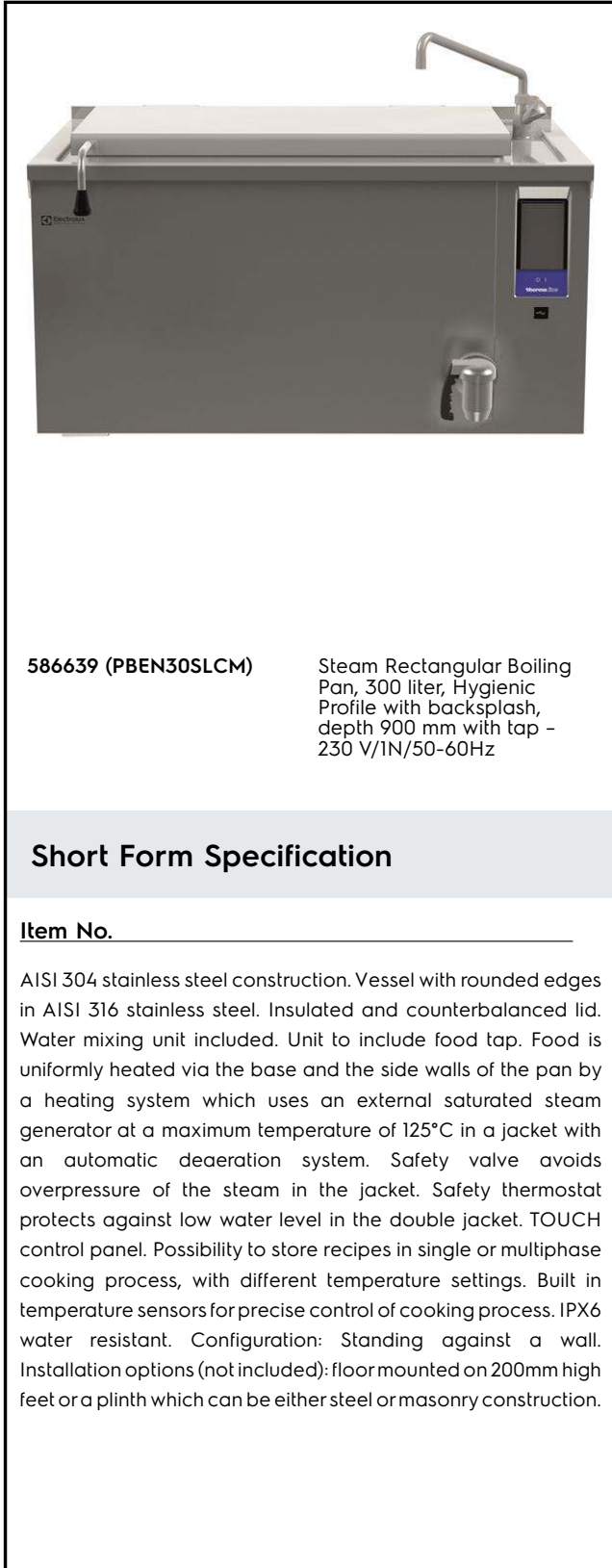
**586639 (PBEN30SLCM)**

 Steam Rectangular Boiling  
 Pan, 300 liter, Hygienic  
 Profile with backsplash,  
 depth 900 mm with tap -  
 230 V/1N/50-60Hz

### Short Form Specification

#### Item No.

AISI 304 stainless steel construction. Vessel with rounded edges in AISI 316 stainless steel. Insulated and counterbalanced lid. Water mixing unit included. Unit to include food tap. Food is uniformly heated via the base and the side walls of the pan by a heating system which uses an external saturated steam generator at a maximum temperature of 125°C in a jacket with an automatic deaeration system. Safety valve avoids overpressure of the steam in the jacket. Safety thermostat protects against low water level in the double jacket. TOUCH control panel. Possibility to store recipes in single or multiphase cooking process, with different temperature settings. Built in temperature sensors for precise control of cooking process. IPX6 water resistant. Configuration: Standing against a wall. Installation options (not included): floor mounted on 200mm high feet or a plinth which can be either steel or masonry construction.

### Main Features

- Kettle is suitable to boil, steam, poach, braise or simmer all kinds of produce.
- Square inner kettle allows working with stacked Gastronorm containers, which facilitate loading and unloading operations.
- Produce is uniformly heated in the vessel by an indirect heating system using saturated steam.
- Isolated upper well rim avoids risk of harm for the user.
- Large capacity food tap enables safe and effortless discharging of contents.
- Self-contained steam-source: a booster feeds steam directly into the double jacket.
- Discharge tap is very easy to disassemble and clean.
- IPX6 water resistant.
- Built in temperature sensor to precisely control the cooking process.
- USB connection to easily update the software, upload/download recipes and download HACCP data.

### Construction

- Cooking vessel in 1.4435 (AISI 316L) stainless steel. Double-jacket in 1.4404 (AISI 316L) stainless steel designed to operate at a pressure of 1.5 bar.
- External panelling and internal frame made of 1.4301 (AISI 304) stainless steel.
- External steam feeding; 1,5 bars working pressure.
- 2" diameter discharge tap for rapid emptying of the well.
- Integrated water mixing tap to make water filling and pan cleaning operations easier.
- Minimised presence of narrow gaps for easier cleaning of the sides to meet the highest hygiene standards.
- Can be prearranged for energy optimisation or external surveillance systems (optional).
- GuideYou Panel - activated by the user via settings - to easily follow the multiphase recipes, granting a proper and controlled cooking and a better appliance optimization. The system will provide maintenance reminders, in line with ESSENTIA program, helping the user to properly take care of the product, avoiding downtimes.
- Highly-visible and bright led TOUCH control panel features user-friendly icons and intuitive self-explanatory command options. Display visualizes:
  - Actual and set temperature
  - Set and remaining cooking time

APPROVAL: \_\_\_\_\_

- Pre-heating phase (if activated)
- GuideYou Panel (if activated)
- Deferred start
- Soft Function to reach the target temperature smoothly
- 9 Power Control levels from simmering to fierce boiling
- Pressure mode (in pressure models)
- Stirrer ON/OFF settings (in round boiling models)
- Error codes for quick trouble-shooting
- Maintenance reminders

### Sustainability



- High-quality thermal insulation of the pan saves energy and keeps operating ambient temperature low.

### User Interface & Data Management

- Connectivity ready for real time access to connected appliances from remote and data monitoring (requires optional accessory – contact the Company for more details).

### Optional Accessories

- Strainer for dumplings for all tilting & stationary braising and pressure braising pans (except 80lt) and for all stationary rectangular and 100lt round boiling pans PNC 910053
- Scraper for dumping strainer for boiling and braising pans PNC 910058
- Base plate for 300lt rectangular boiling pans PNC 910183
- Suspension frame GN1/1 for rectangular boiling and braising pans PNC 910191
- Manometer kit for stationary boiling pans - long - factory fitted PNC 912120
- Power Socket, CEE16, built-in, 16A/400V, IP67, red-white - factory fitted PNC 912468
- Power Socket, CEE32, built-in, 32A/400V, IP67, red-white - factory fitted PNC 912469
- Power Socket, SCHUKO, built-in, 16A/230V, IP68, blue-white - factory fitted PNC 912470
- Power Socket, TYP23, built-in, 16A/230V, IP55, black - factory fitted PNC 912471
- Power Socket, TYP25, built-in, 16A/400V, IP55, black - factory fitted PNC 912472
- Power Socket, SCHUKO, built-in, 16A/230V, IP55, black - factory fitted PNC 912473
- Power Socket, CEE16, built-in, 16A/230V, IP67, blue-white - factory fitted PNC 912474
- Power Socket, TYP23, built-in, 16A/230V, IP54, blue - factory fitted PNC 912475
- Power Socket, SCHUKO, built-in, 16A/230V, IP54, blue - factory fitted PNC 912476
- Power Socket, TYP25, built-in, 16A/400V, IP54, red-white - factory fitted PNC 912477

- Measuring rod and strainer for 300lt stationary rectangular boiling pans PNC 912482
- Connecting rail kit for appliances with backsplash, 900mm PNC 912499
- Set of 4 feet for stationary units (height 200mm) - factory fitted PNC 912732
- Automatic water filling (hot and cold) for stationary units (width 700-1000mm): rectangular pressure boiling and braising pans - factory fitted PNC 912736
- Kit energy optimization and potential free contact - factory fitted PNC 912737
- Mainswitch 25A, 2.5mm<sup>2</sup> - factory fitted PNC 912739
- External touch control device for stationary units - factory fitted PNC 912783
- Wall mounting kit for stationary units - factory fitted PNC 912788
- Connecting rail kit for appliances with backsplash: modular 90 (on the left) to ProThermetic tilting (on the right), ProThermetic stationary (on the left) to ProThermetic tilting (on the right) PNC 912981
- Connecting rail kit for appliances with backsplash: modular 90 (on the right) to ProThermetic tilting (on the left), ProThermetic stationary (on the right) to ProThermetic tilting (on the left) PNC 912982
- Rear closing kit for stationary units with backsplash - factory fitted PNC 912992
- Stainless steel plinth for stationary units - against the wall - factory fitted PNC 913310
- Kit endrail and side panels, flush-fitting, for installation with backsplash, left - factory fitted PNC 913382
- Kit endrail and side panels, flush-fitting, for installation with backsplash, right - factory fitted PNC 913383
- Kit endrail and side panel (12.5mm), for installation with backsplash, left - factory fitted PNC 913406
- Kit endrail and side panel (12.5mm), for installation with backsplash, right - factory fitted PNC 913407
- Drain standpipe for boiling pans (PBEN20/30/40 & PPEN20/30) PNC 913429
- Connectivity kit for ProThermetic Boiling and Braising Pans ECAP - factory fitted PNC 913577

Front

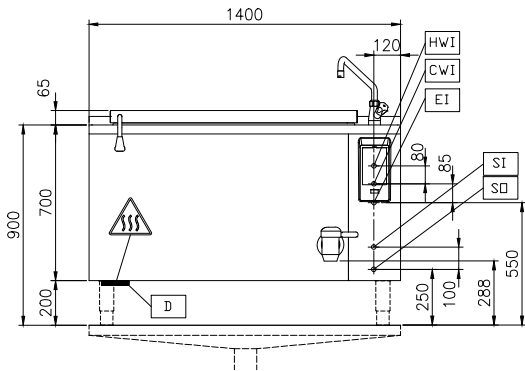

Side

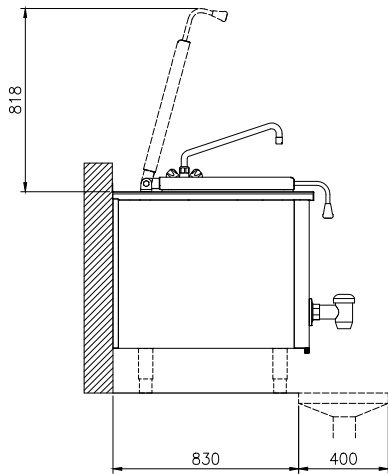

CWI = Cold Water inlet 1 (cleaning)  
 EI = Electrical inlet (power)  
 HWI = Hot water inlet

Top

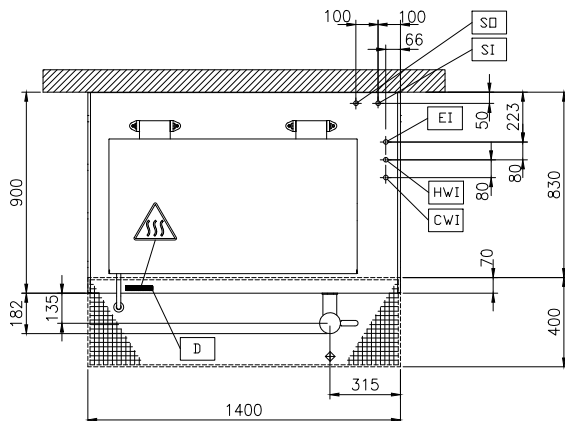

### Electric

Supply voltage: 230 V/1N ph/50/60 Hz  
 Total Watts: 0.3 kW

### Steam

Steam generation: External source  
 Steam inlet size: 1"  
 Condensation outlet size: 1"  
 Steam pressure Max: 1.5 bar  
 Steam supply, relative dynamic pressure: 1 min bar, 1.5 max bar

### Water:

Pressure, min-max: 2-6 bar

### Installation:

FS on concrete base; FS on feet; On base; Standing against wall; Wall mounted (with wall-kit)

### Type of installation:

### Key Information:

Working Temperature MIN: 50 °C  
 Working Temperature MAX: 110 °C  
 Vessel (rectangle) width: 1056 mm  
 Vessel (rectangle) height: 571 mm  
 Vessel (rectangle) depth: 556 mm  
 External dimensions, Width: 1400 mm  
 External dimensions, Depth: 900 mm  
 External dimensions, Height: 700 mm  
 Net weight: 285 kg  
 Configuration: Rectangular; Fixed; With splashback  
 Net vessel useful capacity: 300 lt  
 Double jacketed lid: ✓  
 Heating type: Indirect

### Sustainability

Steam consumption: 130 kg/hr